

产品特点

- 为棒型、横置式有源静电消除器；
- 棒体小巧，造型美观；
- 在高电压、微电流（ μA 级）状态下工作；
- 具有防电击功能，避免人体意外触碰导致伤害；
- 棒体背部特制条形槽口，安装螺栓可移动；

Product Features

- Stick/horizontal type active electrostatic eliminator;
- Small size, convenient installation;
- Operating under high voltage and micro current (μA);
- Protecting against electric shock and avoiding injury caused by human body's accidental touch;
- Special bar groove is made on the back of the bar body, and the mounting bolts can be moved;



额定规格/性能 Ratings and Specifications

型号Model	SE-FQ600-L □
电源电压 Power supply voltage	input AC220V
功率 power	20W
离子发射ion emission	工频交流POWER frequency AC
发射电极emission electrode	SUS
放电结构discharge structure	电阻耦合resistance coupling
消电范围 discharge range	L*W*H (150mm→3000mm) *300mm*600mm
安装距离mounting distance	100→600mm
离子平衡度 Ionic balance	$\leq \pm 100\text{V} $
消电速度discharge speed	$\leq 2.5\text{S}$ (工作距离working distance 300mm, 气流压力air pressure 0.3MPa)
气流压力air pressure	$\leq 0.6\text{MPa}$
带节流阀throttle valve/气源接头air supply connector	$\Phi 8\text{-G}1/8$ 黑色black
工作温度 temperature	$0^\circ\text{C} - 50^\circ\text{C}$
工作湿度humidity	$< 70\%$
外形尺寸dimension	L*W*H (150mm→3000mm) *28.6mm*38.7mm
棒体材质housing material	阻燃flame-resistant PVC、SUS
高压连接线长度 cable length	2.5m (可按要求定制customized)

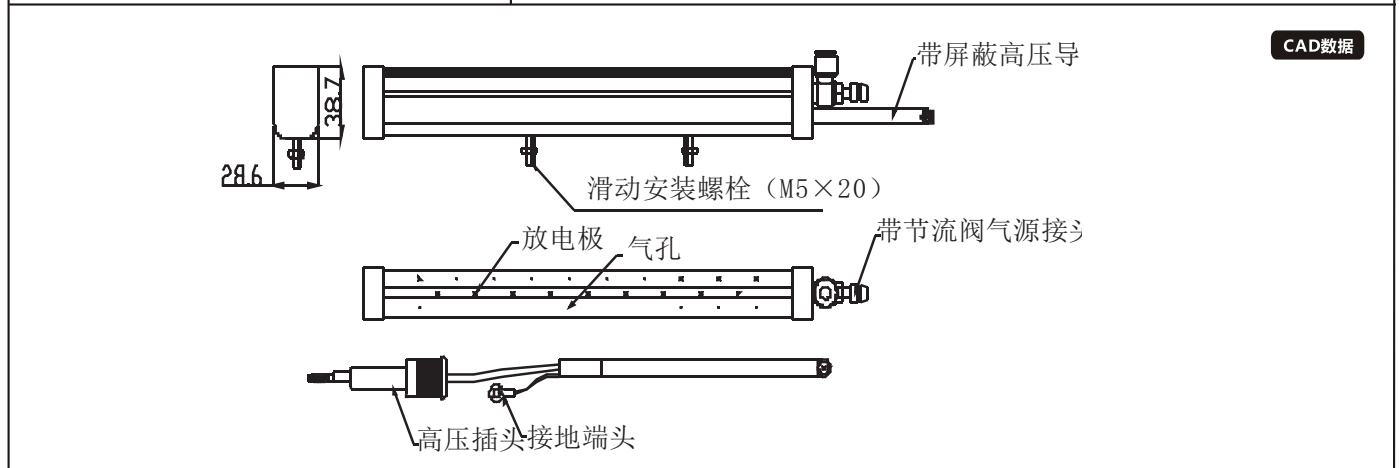

备注：使用离子棒时，应将其放置于被消除静电的工作区域内。（距被消静电物体表面约30~100mm处为佳）安装角度应垂直于带电体表面。
 Note: When using the eliminator, it should be placed in the working area where the static electricity is being eliminated (it is better to be about 30~100mm away from the surface of the electrostatic object). The mounting Angle should be perpendicular to the surface of the charged body.